

10.4" Touchscreen Liquid Crystal Display



Introduction

The E-PLEX® 350LCD series is a family of liquid crystal displays that have been designed to give the customer a choice of desired features without requiring a traditional operating system on a PC. An integrated touch screen interface allows for monitoring and controlling of different key subsystems, all from one location.

In addition to the system display and control features, the 350LCD series module can double as a video display for inputs from satellite TV, VCR, DVD, DVR, video game consoles, security cameras, and any other video source that supports RCA and S-Video connectivity. For example, you can watch your favorite DVD on the 350LCD, and with a quick touch of the screen, all the controls and monitoring of your system are available for you to access.

Key Features

- ◆ 640 x 480 color display
- ◆ 10.4" Diagonal transmissive display
- ◆ Supports NTSC and PAL video formats
- ◆ Integrated resistive touch screen
- ◆ Up to 800 x 600 resolution with VGA (DB15) out connection

Design Specifications

- ◆ Shock (non-operating): Maximum of 50G, pulse width of 11ms with a half sine wave, $\pm X$, $\pm Y$, $\pm Z$ once in each direction
- ◆ Moisture resistance : IP50
- ◆ PCB characteristics : UL94V-0
- ◆ Vibration: (non-operating): Frequency of 10~57Hz with vibration width (one side) of 0.075mm, 58~500 Hz with 1G sweep time of 11 minutes, 3 hours duration (1 hour for each direction X, Y, Z)

Electrical Specifications

Voltage	7VDC to 32VDC
Current, Total	0.75A to 2A
Electroluminescent (EL) Backlight	2CCFT (E)
Display Size	260mm (10.4 in)
Dot Format (HxV)	640 x 480 dot (RGB)
Dot Pitch (HxV)	0.11 mm x 0.33 mm
Colors	262,144 colors
Brightness	250 cd/m ²
Contrast Ratio	70:1 (transmissive mode)
Power Consumption	6.8W

Physical Specifications

Front Bezel	Polycarbonate
Back Cover	Stainless Steel
PC Board	ULV94-0 FR4
Mounting Bracket	Stainless Steel
Operating Temperature	0°C to 60°C
Storage Temperature	-30°C to 70°C
Operating Humidity	5% to 90% (non-condensing RH)
Weight	2.38 lb (38 ounces)
Overall Length	7.8" (198.1 mm)
Overall Width	10.4" (264.2mm)
Overall Height	1.99" (50.5mm)
Recommended Wire Specification for E-Plex Twisted Pair ¹	16 AWG (1.3 mm) - Unshielded, twisted pair General purpose: Belden 1035 A - Non-tinned Marine: Belden 9410 - Tinned

Wiring Specifications

Terminal Connector Specifications	Tin-plated male 0.250" quick-connect tabs
Mating Connector Specification	0.250" female spade terminal

NOTE:

1. Unrestricted topology: Star, Tree, Daisy Chain configurations all valid.

Typical Wiring Instructions

Recommended Wire Gauge	16 AWG (1.6 mm ²)
Terminal Connector	0.25" tin plated male quick-connect tabs
RCA Video Input	Standard RCA cable/jack
S-Video Input	Standard S-Video cable
VGA Input	Standard male D-Sub 15 VGA cable

Connection Specifications

Pin #	Pin Description	Inputs & Outputs	Remarks
1	E-Plex Data Bus + (grey)	I / O	20 mA max E-Plex load
2	E-Plex Data Bus - (purple)	I / O	20 mA max E-Plex load
3	Battery + (red)	I	Max 2A draw
4	RCA Video 1	I	—
5	RCA Video 2	I	—
6	RCA Video 3	I	—
7	RCA Video 4	I	—
8	S-Video 1	I	—
9	S-Video 2	I	—
10	VGA	O	—

Typical Wiring Diagram

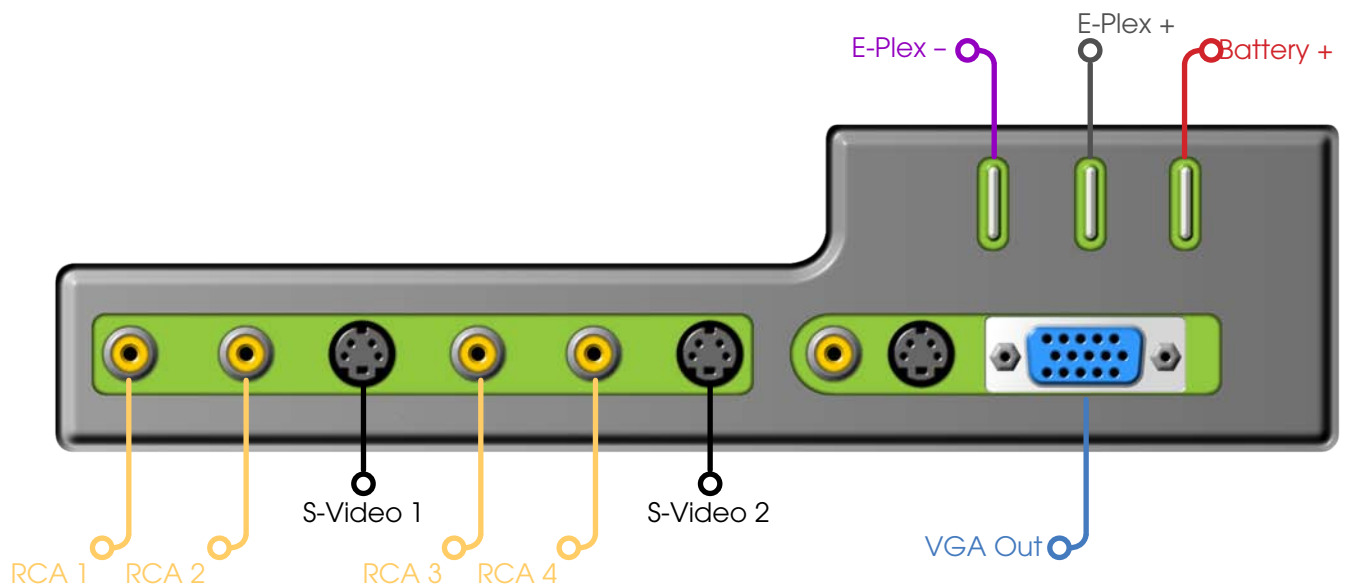

Mounting Specifications

350LCD“X”-001

(Does not include the bezel or back cover or mounting bracket)

This is for situations when the customer has an enclosure that they wish to mount the module into. Note: Lack of a back cover negates EMI rating. The opening should be 10.45" X 7.58". The depth is approx 1.20". Make sure there is enough room for the coax connections to come out the back side.

To mount, use a 6-32 stainless steel screw and a 6-32 lock washer in the four places shown below. Make sure panel/enclosure is in between machine screw/lock washer and standoff. Torque to 7~10 in-lb.

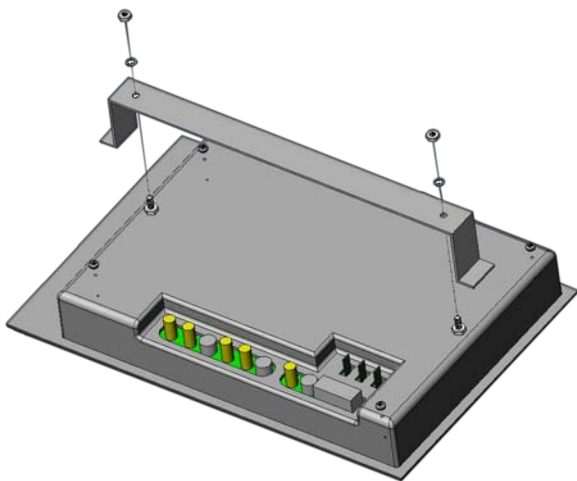
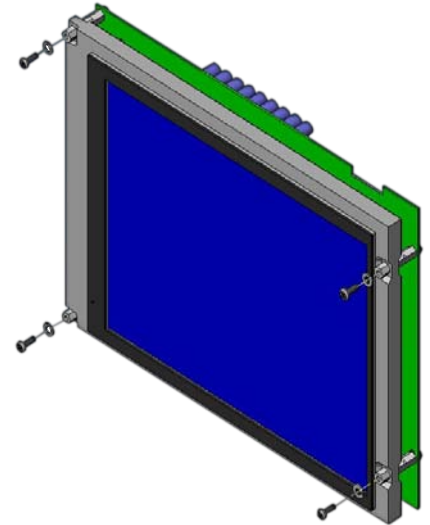

350LCD“X”-001

(Includes bezel, back cover, mounting bracket)

This is for situations when the customer wants to mount the unit into a wall or panel directly. The opening should be 11.05" X 7.91". The depth is approx 2.36". Make sure there is enough room for the coax connections to come out the back side.

To mount, remove the bracket that is on the back side of the module. Place the module into the panel opening cut to the dimensions specified above. Place the module into the opening. Place the bracket back onto the module. Make sure that the holes in the bracket are inserted through the two screws protruding out of the back cover. Using two 8-32 nuts with lock washers, torque to 12~15 in lb.

350LCD“X”-003

(Includes back cover only, no front bezel or mounting bracket)

This is for situations when the customer wants to mount the module to their own custom panel from the front side and wants a back cover to help protect the module. The opening should be 11.05" X 7.91". The depth is approx 1.76". Make sure there is enough room for the coax connections to come out the back side.

To mount, use a 6-32 stainless steel screw and a 6-32 lock washer in the four places shown below. Make sure panel is in between machine screw/lock washer and standoff. Torque to 7~10 in-lb.

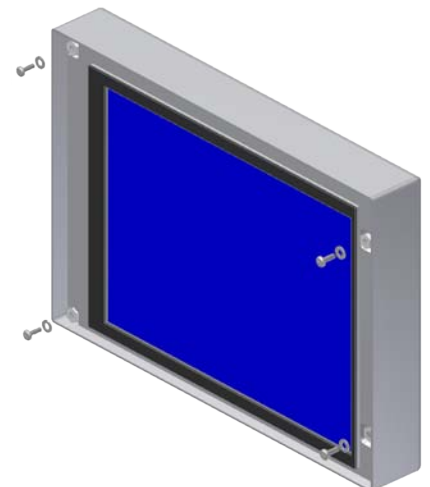

Dimensional Diagram (350LCD"X" -001)

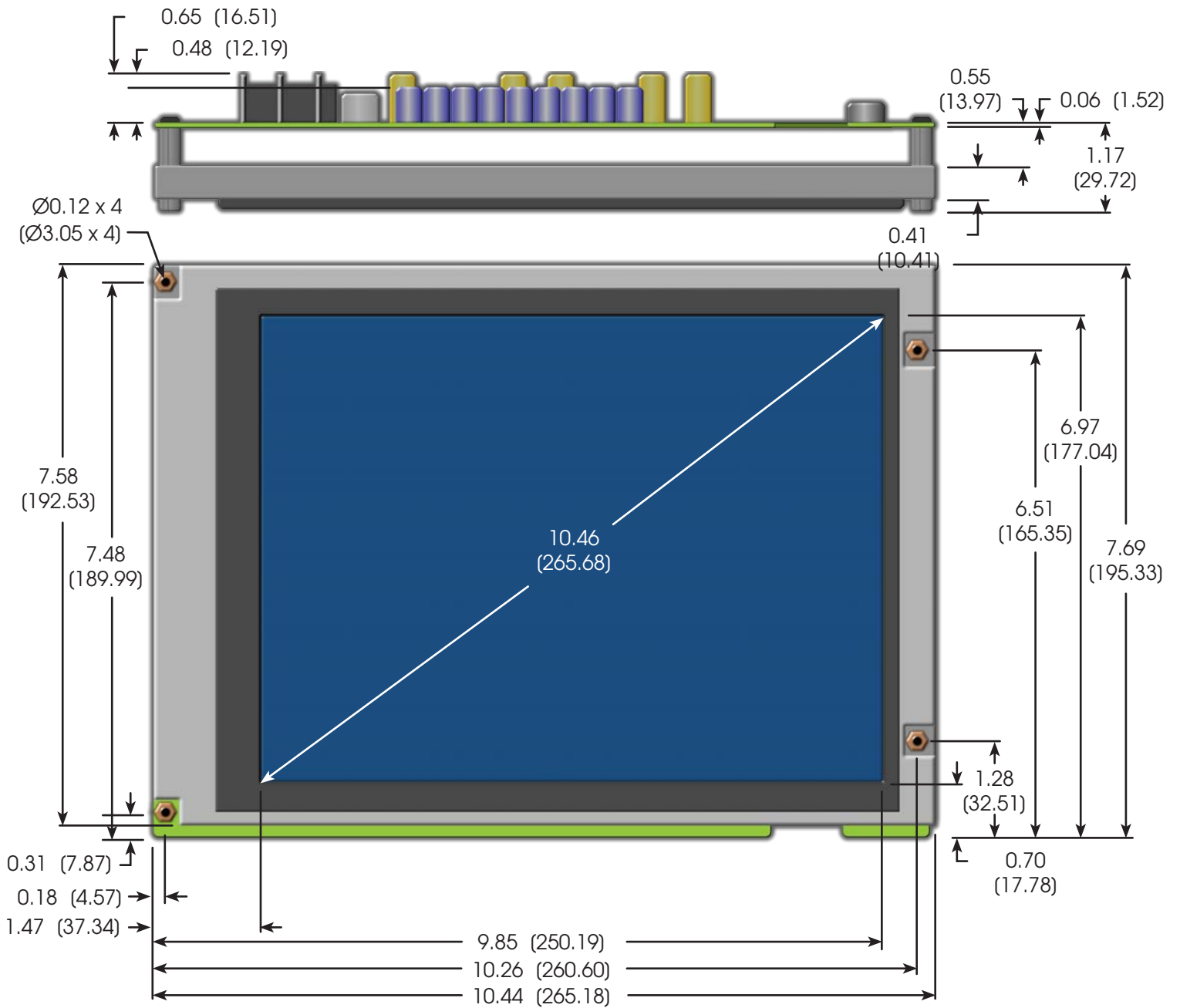

Dimensional Diagram (350LCD "X" -002)

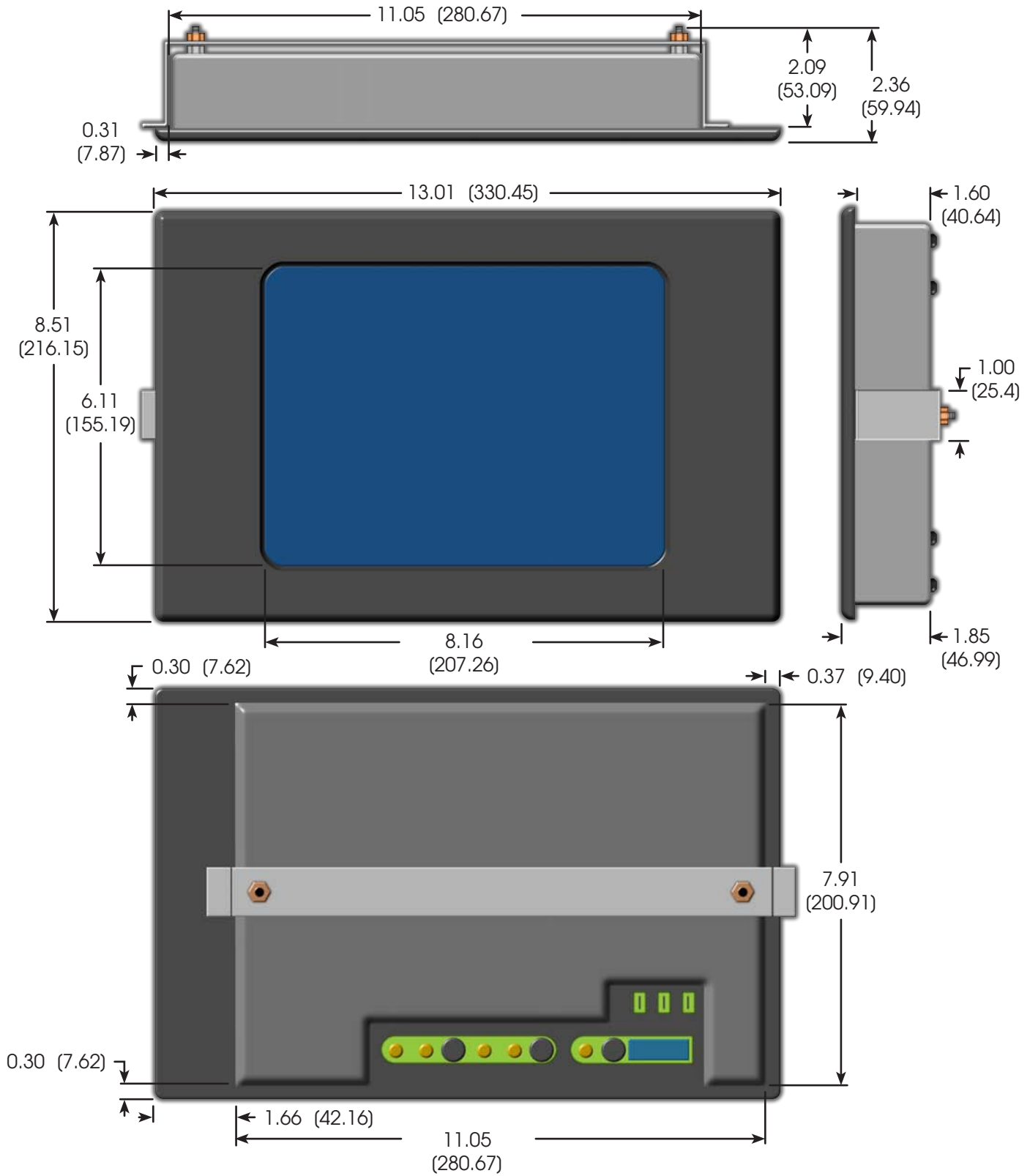

Dimensional Diagram (350LCD"X" -003)

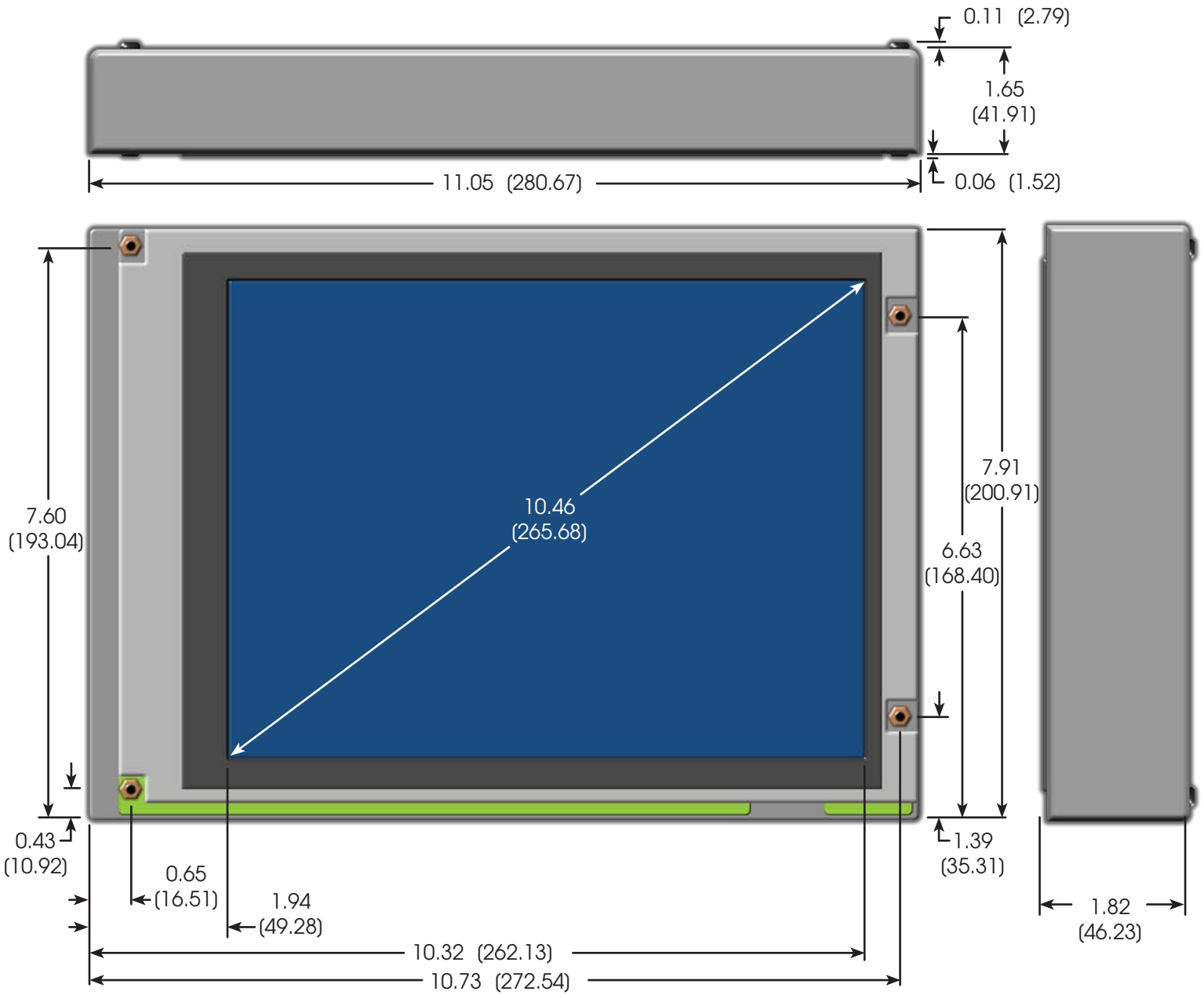

Part Number Specification

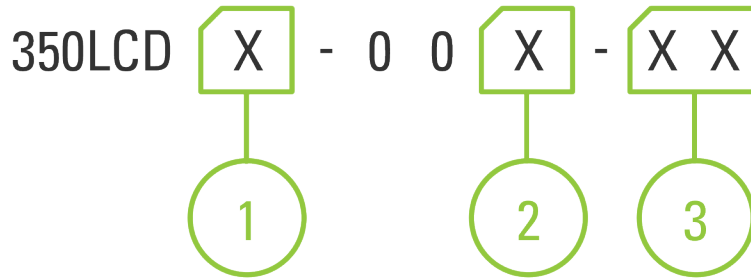

STEP 1 Choose Display Options

CODE	DESCRIPTION
1	Transmissive display (inside / low ambient light conditions)
2	Transflective display (outside / high ambient light conditions)

STEP 2 Choose Mounting / Body Options

CODE	DESCRIPTION
1	Does not include the bezel, back cover or mounting bracket
2	Includes bezel, back cover, mounting bracket
3	Includes back cover only, no front bezel or mounting bracket

STEP 3 If Step 2 choice is code "2", choose bezel color from the Standard Bezel Color Options below. Use 2-digit code after the "-" dash for PN.

Ordering Information

Description	ED&D Part Number
350LCD Series - 10.4" Touchscreen LCD	350LCD-00X
Customer Defined Bezel (see below)	MC0103-XX

Standard Bezel Options

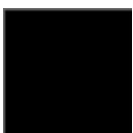

Flat Black Bezel
MC0103-FB



Black Gloss Bezel
MC0103-GB



Soft Gold Satin Bezel
MC0103-SG



Grey Gloss Bezel
MC0103-GR

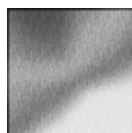

Metallic Nickel Gloss Bezel
MC0103-NI

